

Homecoming



Ditre
Italia



1976 — 2026
Design Beyond Time



Ogni divano è espressione del suo tempo. E nasce sempre da un gesto.



(IT) Da più di cinquant'anni Ditre Italia confeziona divani come si cuciono abiti: su misura, secondo lo spirito del tempo. È un atelier industriale che concepisce il divano come un testimone di cultura, e ogni dettaglio come una dichiarazione d'intenti. Nell'attraversare diverse epoche storiche ha sempre saputo interpretare, con la propria voce, un'idea di eleganza.

(EN) Every sofa is an expression of its time. And the product of consummate craftsmanship. For over fifty years, Ditre Italia has been creating sofas like the finest tailored garments: made to measure and embodying the spirit of the time. Ditre Italia is an industrial studio that regards the sofa as a cultural legacy, and every detail as a declaration of intent. Over the course of different historical periods, it has always communicated its own concept of elegance.

(ES) Cada sofá es la expresión de su tiempo. Y nace siempre de un ademán. Ditre Italia lleva más de cincuenta años confeccionando sofás con un planteamiento similar al de la costura: a medida y según las tendencias del momento. Es un taller industrial que concibe el sofá como un testimonio de la cultura, y cada detalle como una declaración de intenciones. A su paso por diversas épocas históricas, siempre ha sabido transmitir, con su propia voz, una idea de elegancia.

(FR) Chaque canapé est l'expression de son époque. Et il naît toujours d'un geste. Depuis plus de cinquante ans, Ditre Italia confectionne des canapés comme des vêtements : sur mesure, en phase avec l'esprit de l'époque. C'est un atelier industriel qui conçoit le canapé comme un témoin de la culture, et chaque détail comme une déclaration d'intention. À travers différentes époques historiques, il a toujours su interpréter, avec sa propre voix, une idée d'élégance.

Il mondo analogico.
Agli albori di un'idea.



L'energia di fine secolo.
Desiderio e tecnologia.



(IT) Ditre Italia è l'erede di una tradizione che vede agire, nel processo di realizzazione di un manufatto, mani esperte e occhi attenti al dettaglio. In un'epoca di rivoluzioni culturali, tra anticonformismo e avanguardia, è testimone dell'ingresso nel mondo dell'imbottito di nuove matericità, e di una ritrovata libertà di forme e volumi.

(EN) **The analogue world. The origins of an idea.** Ditre Italia adopts a traditional approach to production, based on skilled craftsmanship and painstaking attention to detail. At a time of cultural revolution, nonconformity and innovation, it is synonymous with the emergence of new textures in the world of upholstered furniture, as well as a new-found freedom of forms and dimensions.

(ES) **El mundo analógico. En los albores de una idea.** Ditre Italia es heredera de una tradición donde el proceso de fabricación de un producto requiere la pericia de manos expertas y ojos atentos a los detalles. En una era de revoluciones culturales, que van del inconformismo a la vanguardia, es testigo de la introducción en el mundo de los tapizados de nuevos materiales y de una renovada libertad de formas y volúmenes.

(FR) **Le monde analogique. À l'aube d'une idée.** Ditre Italia s'inscrit dans une tradition où des mains expertes et le souci du détail sont à l'œuvre dans le processus de réalisation d'un produit. À l'ère des révolutions culturelles, entre anticonformisme et avant-garde, elle témoigne de l'arrivée dans le monde du rembourrage de nouveaux matériaux et d'une liberté retrouvée en matière de formes et de volumes.

(IT) All'avvicinarsi della fine del secolo, nella manifattura si fa sentire il richiamo dell'innovazione con l'ingresso della tecnologia. Ditre Italia inizia a parlare di "sartorialità industriale" per indicare un approccio che unisce design di qualità e dimensione industriale. L'azienda vive un momento di grande energia e uno sviluppo euforico, già pronta per il futuro.

(EN) **End-of-century energy. Desire and technology.** As the end of the millennium draws near, the introduction of new technologies brings innovation to manufacturing. Ditre Italia begins to refer to "industrial tailoring" to indicate an approach that combines quality design with mass production. The company enjoys a period of great fervour and development as it sets its sights on the future.

(ES) **La energía de fin de siglo. Deseo y tecnología.** Al tocar a su fin el siglo, en la producción resuena el clamor de la innovación con la integración de la tecnología. Ditre Italia empieza a hablar de «confección industrial» para expresar un enfoque que combina diseño de calidad y escala industrial. La empresa vive un momento de gran energía y un desarrollo eufórico, preparada para el futuro.

(FR) **L'énergie de la fin du siècle. Désir et technologie.** À l'approche de la fin du siècle, l'appel à l'innovation se fait sentir dans le secteur manufacturier avec l'arrivée de la technologie. Ditre Italia commence à parler de « confection industrielle » pour désigner une approche qui allie design de qualité et dimension industrielle. L'entreprise traverse une période d'énergie débordante et de développement euphorique, et se prépare déjà pour l'avenir.

La contemporaneità.
Ciò che serve, ciò che dura.



Uno sguardo al futuro.
Etica della bellezza e lusso silenzioso.



(IT) Con il nuovo millennio si fanno strada stili di vita più consapevoli, che privilegiano filosofie sostenibili, estetiche senza tempo e oggetti durevoli. Forme eleganti, fluide, organiche – è questa la bellezza destinata a durare. La casa si apre alla pianta libera e il living, con il divano, dialoga con la cucina.

(EN) **The contemporary era. Things that people need, things that last.** With the new millennium, people adopt more conscious lifestyles, prioritising sustainable philosophies, timeless aesthetics and durability. Elegant, fluid, organic forms for a beauty that stands the test of time. Homes are designed as open spaces and the living room and sofa dialogue with the kitchen.

(ES) **La modernidad. Lo que se necesita, lo que dura.** Con el nuevo milenio surgen estilos de vida más concienciados, que priorizan las filosofías sostenibles, las estéticas imperecederas y los artículos duraderos. Formas elegantes, fluidas y orgánicas: esta es la belleza destinada a durar. El hogar se abre a la planta libre, y el salón dialoga con la cocina a través del sofá.

(FR) **La contemporanéité. Ce qui est nécessaire, ce qui dure.** Avec l'avènement du nouveau millénaire, des modes de vie plus conscients émergent, privilégiant les philosophies durables, une esthétique intemporelle et des objets durables. Des formes élégantes, fluides et organiques – une beauté faite pour durer. La maison s'ouvre sur un espace libre et le salon, avec son canapé, communique avec la cuisine.

(IT) La bellezza etica è per sua stessa natura anti-effimera. Si concede di invecchiare, assumendo una patina che la rende unica, speciale, più interessante quanto più passa il tempo. Il vero lusso è sapere come qualcosa è fatto, e da chi. Perché alla fine è il tempo, la pienezza del tempo, l'unico valore che conta.

(EN) **Looking to the future. The ethics of beauty and silent luxury.** Ethical beauty is inherently nonephemeral. It accepts ageing, taking on a patina that makes it unique, special and more interesting as time goes by. True luxury is knowing how something is made, and by whom. Because, at the end of the day, time, the fullness of time, is the only thing that matters.

(ES) **Una mirada al futuro. Ética de la belleza y lujo sutil.** La belleza ética es, por su propia naturaleza, antieffimera. Se permite envejecer, adquiriendo una patina que la hace única, especial, más interesante cuanto más tiempo pasa. El auténtico lujo es saber cómo se ha hecho algo y quién es su autor. Porque, a fin de cuentas, es el tiempo, con su plenitud, el único valor que cuenta.

(FR) **Un regard vers l'avenir. Éthique de la beauté et luxe discret.** La beauté éthique est par nature anti-éphémère. Elle se permet de vieillir, acquérant une patine qui la rend unique, spéciale, plus intéressante avec le temps. Le vrai luxe, c'est de savoir comment quelque chose est fabriqué et par qui. Car au final, c'est le temps, la plénitude du temps, la seule valeur qui compte.

Homecoming

Ditre Italia presenta un nuovo strumento che guarda al mondo dei magazine per superare la dimensione del prodotto e raccontare l'arte del vivere. Dentro spazi reali, abitati da persone vere, divani, poltrone e complementi mostrano tutte le potenzialità estetiche di un design che è un tributo alla bellezza e all'autenticità, rivelando cosa significa, per ciascuno di noi, sentirsi a casa.

(EN) Ditre Italia has created a new tool, inspired by the world of printed magazines, to take its product beyond the physical dimension and tell stories about the art of domestic living. Inside real spaces, home to real people, these sofas, armchairs and pieces of furniture showcase the full aesthetic potential of design that is an ode to beauty and authenticity, revealing what it means, for each of us, to feel at home.

(ES) Ditre Italia presenta una nueva herramienta que se inspira en el mundo de las revistas para trascender el concepto de producto y transmitir el arte del hogar. Dentro de espacios reales, donde viven personas de verdad, los sofás, sillones y complementos revelan todo el potencial estético de un diseño que rinde tributo a la belleza y a la autenticidad, expresando qué significa, para cada uno de nosotros, sentirse en casa.

(FR) Retour à la maison. Ditre Italia présente un nouvel outil qui, s'inspirant du monde des magazines, transcende la dimension produit et raconte l'art de vivre. Dans de véritables espaces, habités par de vraies personnes, canapés, fauteuils et compléments montrent tout le potentiel esthétique d'un design qui rend hommage à la beauté et à l'authenticité, en révélant ce que signifie pour chacun d'entre nous se sentir chez soi.

Racconto di due case

La casa come luogo a cui tornare.
Dopo il lavoro o dopo un viaggio, la sensazione
di entrare in uno spazio tutto nostro,
in cui riconosciamo ogni dettaglio, e ogni oggetto
parla di noi e della vita che abbiamo scelto.



(P. 012)
Dove la città si fa casa
e la storia si esprime



(P. 046)
Dove la natura accoglie e
dà spazio al contemporaneo

(EN) A tale of two homes.
Home is the place we always
return to. At the end of the
day, after work, or after a trip
away, we step back into
a space that is our own,
where every detail is familiar
and every object represents
who we are and the life we
have chosen to live.

(ES) Una historia de dos casas.
El hogar como lugar al que
regresar. Después del trabajo
o al volver de un viaje,
la sensación de entrar en un
espacio totalmente nuestro,
donde reconocemos cada
detalle y cada pieza, habla
de nosotros y de la vida que
hemos elegido.

(FR) L'histoire de deux maisons.
La maison comme lieu où
revenir. Après le travail ou un
voyage, la sensation d'entrer
dans un espace qui nous
est propre, où l'on reconnaît
chaque détail, où chaque
objet parle de nous et de la
vie que nous avons choisie.



Dove la città si fa casa e la storia si esprime

(EN) When the city
becomes home
and history speaks

(ES) Donde la ciudad
se hace hogar y se
expresa la historia

(FR) Là où la ville
devient maison et où
l'histoire s'exprime

Quando sei lontana è qui che vuoi tornare. Dove non
ci sono impegni di lavoro, né obblighi sociali di alcun tipo.
Ci sei solo tu, mentre fuori cala il sole.

(EN) When you're away,
it's where you long to
be. A place with no work
commitments or social
obligations. Just you,
the sun setting outside
the window.

(ES) Cuando estás lejos, es
aquí adonde quieres volver.
Donde no hay obligaciones
del trabajo ni compromisos
sociales de ningún tipo.
Estás a solas, mientras fuera
luce el sol.

(FR) Quand on est loin, c'est
ici qu'on a envie de revenir.
Là où il n'y a ni engagements
professionnels, ni obligations
sociales d'aucune sorte.
Il n'y a que vous, tandis que
le soleil se couche dehors.



Divano NUBE. Composizione 3.
L 301 P 272 H 75 cm: terminale inclinato dx,
angolo aperto, terminale 1 posto sx.
Rivestimento in tessuto Ubud 01.
Poltrona MANTA, tavolini MEKKI,
madia bassa PETRA, tappeto GLINT.

NUBE Sofa. Composition 3.
W 301 D 272 H 75 cm: right slanted
terminal element, open corner, left 1-er terminal
element. Upholstery in Ubud 01 fabric.
MANTA armchair, MEKKI coffee tables,
PETRA low sideboard, GLINT carpet.



Divano NUBE. Composizione 2.
L 412 P 272 H 75 cm: terminale
inclinato dx, angolo aperto,
centrale 1 posto, terminale 1 posto sx.
Rivestimento in tessuto Ubud 01.
Poltrona MANTA, tavolini MEKKI,
madia bassa PETRA, tappeto GLINT.

NUBE sofa. Composizione 2.
W 412 D 272 H 75 cm: right slanted
terminal element, open corner,
1-er central element, left 1-er terminal
element. Upholstery in Ubud 01 fabric.
MANTA armchair, MEKKI coffee tables,
PETRA low sideboard, GLINT carpet.



Piccoli rituali senza i quali la vita non sarebbe la stessa:
il primo caffè del mattino, sorseggiato con calma mentre
sfogli il giornale o leggi qualche pagina di un libro.

(EN) Rituals that make
life what it is: the first sip
of your morning coffee,
while reading the
newspaper or a few pages
of a good book.

(ES) Sin estos pequeños
rituales la vida no sería
lo mismo: el primer café
de la mañana, paladeado
con calma mientras hojeas
el periódico o lees páginas
de un libro.

(FR) Ces petits rituels sans
lesquels la vie ne serait
pas la même : le premier
café du matin, siroté
tranquillement en feuilletant
le journal ou en lisant
quelques pages d'un livre.





Piano in legno finitura Grey Wood LE12.
Wooden top in Grey Wood LE12 finish.

Divano DECK. Composizione 1.
L 412 P 410 H 83 cm: chaise longue
maxi sx, centrale 1 posto maxi,
angolo tondo maxi, centrale
1 posto maxi, laterale 1 posto
maxi dx con piano in legno.
Rivestimento in tessuto Primula 901.
Poltrona 356 SWIVEL,
tavolino DECK, tavolino NELL,
tappeto GLINT.

DECK sofa. Composizione 1.
W 412 D 410 H 83 cm: left maxi chaise
longue, 1-er maxi central element,
maxi round corner, 1-er maxi central
element, right 1-er maxi lateral
element with wooden top.
Upholstery in Primula 901 fabric.
356 SWIVEL armchair,
DECK coffee table, NELL coffee table,
GLINT carpet.



Tavolino tondo maxi DECK.
L 120 P 120 H 37 cm.
Rivestimento in pelle Polar 212,
top in marmo Sequoia Brown MA11.

DECK maxi round coffee table.
W 120 D 120 H 37 cm
Upholstery in Polar 212 leather,
marble top in Sequoia Brown MA11.





Prima di essere una casa era la chiesa di un monastero.
È per questa dimensione spirituale che l'hai scelta,
perché per te la casa è uno spazio dell'anima, l'unico
dove puoi essere davvero te stessa.

(EN) It was a monastery church before becoming a home – the spiritual dimension was part of the appeal. Home is a space for the soul, in your eyes, the only place in which you can truly be yourself.

(ES) Antes de ser vivienda era la iglesia de un monasterio. La elegiste precisamente por esta dimensión espiritual, porque para ti el hogar es el espacio del alma, el único donde puedes ser realmente tú misma.

(FR) Avant d'être une maison, c'était l'église d'un monastère. C'est pour cette dimension spirituelle que vous l'avez choisie, car pour vous, la maison est un espace de l'âme, le seul endroit où vous pouvez vraiment être vous-même.

Divano ISLA. Composizione 9.
L 399 P 180 H 83 cm: base chaise
longue maxi, base terminale curva dx.
Rivestimento in tessuto Ubud 09.
Poltrona ISLA, tavolini PETRA,
tavolino AULOS, tappeto GLINT.

ISLA sofa. Composition 9.
W 399 D 180 H 83 cm: maxi chaise
longue base, right curved terminal base.
Upholstery in Ubud 09 fabric.
ISLA armchair, PETRA coffee tables,
AULOS side table, GLINT carpet.







Poltrona ISLA. L 89 P 90 H 74 cm.
Rivestimento in tessuto Malaga 01.

ISLA armchair. W 89 D 90 H 74 cm.
Upholstery in Malaga 01 fabric.

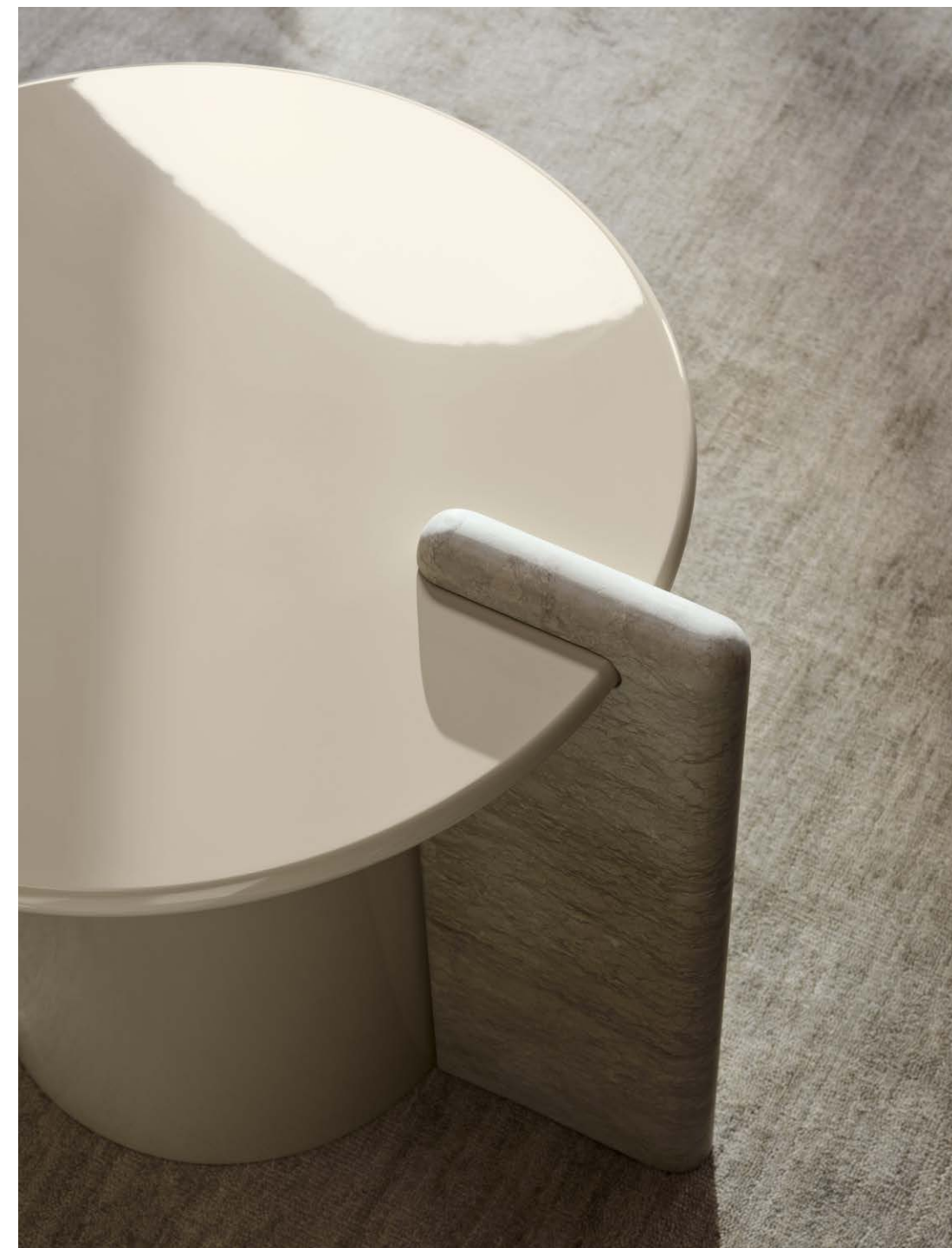

Tavolini PETRA.
 L 160 P 60 H 39 cm:
 tavolino rettangolare.
 L 90 P 90 H 29 cm: tavolino quadro.
 L 50 P 50 H 48 cm: tavolino
 servetto. Struttura in finitura
 laccato Mastice Glossy LE27,
 inserto in marmo Silver Moon MA19.
 Poltrona ISLA, tappeto GLINT.

PETRA coffee tables.
 W 160 D 60 H 39 cm:
 rectangular coffee table.
 W 90 D 90 H 29 cm: square coffee table.
 W 50 D 50 H 48 cm: side table.
 Structure in Mastice Glossy LE27
 lacquered finish, Silver Moon
 MA19 marble decorative element.
 ISLA armchair, GLINT carpet.



Sei un'amante della solitudine, ma non sempre.
A volte organizzzi delle cene o delle piccole feste:
ti piace che la casa si riempia di volti e di voci,
e accolga le persone che ami.

(EN) Solitude is bliss, but not all of the time. You like organising the odd dinner party or evening with friends. You like it when the house fills with familiar faces and voices, welcoming in the people you hold most dearly.

(ES) Eres una amante de la soledad, pero no siempre. A veces organizas cenas o pequeñas fiestas: te gusta que el hogar se llene de rostros y voces y acoja a las personas que quieres.

(FR) Vous aimez la solitude, mais pas toujours. Parfois vous organisez des dîners ou de petites fêtes : vous aimez que votre maison soit remplie de visages et de voix, et accueillir les personnes que vous aimez.

Tavolo COSMOS. L 300 P 120 H 76 cm.
Gambe in finitura laccato Mastice Glossy
LE27, piano in marmo Silver Moon MA19
con inserto centrale in vetro bronzato VE02.
Sedia BLISS, madia alta PETRA,
tappeto GLINT.

COSMOS table. W 300 D 120 H 76 cm.
Legs in Mastice Glossy LE27 lacquered
finish, Silver Moon MA19 marble top
with bronzed glass VE02 central element.
BLISS chair, PETRA high sideboard,
GLINT carpet.





Sedia BLISS. L 55 P 62 H 81 cm.
Rivestimento in tessuto Patch 55.

BLISS chair. W 55 D 62 H 81 cm.
Upholstery in Patch 55 fabric.





Madia alta PETRA.
L 229 P 49 H 72 cm.
Struttura in finitura laccato
Mastice Glossy LE27, inserto
in marmo Silver Moon MA19.

PETRA high sideboard.
W 229 D 49 H 72 cm.
Structure in Mastice Glossy LE27
lacquered finish, Silver Moon MA19
marble decorative element.

Prima di uscire, guardi la tua immagine riflessa
nello specchio. Pacificata e serena dopo aver trascorso
del tempo in uno spazio solo tuo.

(EN) As you leave the house,
you glance fleetingly at your
reflection in the mirror.
Calm and serene. You're at
home.

(ES) Antes de salir,
contemplas tu imagen
reflejada en el espejo.
Despreocupada y tranquila
después de pasar tiempo
en un espacio solo tuyo.

(FR) Avant de sortir, vous
contemplez votre reflet
dans le miroir. Un sentiment
de paix et de sérénité vous
envahit après avoir passé du
temps dans un espace rien
que pour vous.

Specchio U MIRROR. L 80 P 23 H 194 cm.
Struttura in metallo Light Brown ME11.
Poltrona HAIRPIN, panca CLIP.

U MIRROR mirror. W 80 D 23 H 194 cm.
Light Brown ME11 metal structure.
HAIRPIN armchair, CLIP bench.





Dove la natura accoglie e dà spazio al contemporaneo

(EN) Surrounded
by nature in
a contemporary space

(ES) Donde la naturaleza
acoge y da espacio
a lo moderno

(FR) Là où la nature
accueille et laisse place
au contemporain

Vivere in campagna è stato un sogno coltivato
a lungo, e finalmente si è realizzato.
Qui, accorgerti delle stagioni che passano ti porta
a dare un ritmo diverso alle tue giornate.

(EN) Living in the countryside has been a dream for a long time, and now finally it's come true. Being here and watching the seasons pass gives the day a whole other rhythm.

(ES) Vivir en el campo era desde siempre un sueño que, por fin, se ha hecho realidad. Aquí, contemplar el paso de las estaciones te imprime un ritmo distinto del de otros días.

(FR) Vivre à la campagne était un rêve de longue date et il s'est enfin réalisé. Ici, observer le passage des saisons vous amène à donner un rythme différent à vos journées.



Divano NUBE. Composizione 1.
L 309 P 170 H 75 cm: terminale
inclinato sx, laterale 1 posto tondo dx.
Rivestimento in tessuto Tango 20.
Poltrona HAIRPIN, tavolini MEKKI,
madia bassa PETRA, tappeto REED.

NUBE sofa. Composition 1.
W 309 D 170 H 75 cm: left slanted terminal
element, right 1-er round lateral element.
Upholstery in Tango 20 fabric.
HAIRPIN armchair, MEKKI coffee tables,
PETRA low sideboard, REED carpet.



Ogni tanto ami fermarti, sederti e guardare semplicemente le cose attorno a te – oggetti, libri, quadri. Senza scadenze, né pensieri, soltanto tu, nella quiete profonda di casa tua.

(EN) Every now and then, it's good to stop, sit down and just observe the things around you – books, paintings, possessions. No deadlines, no racing thoughts. Just you, deep in the quiet of your home.

(ES) De vez en cuando, te gusta sentarte a observar sin más las cosas que te rodean: objetos, libros, cuadros. Sin plazos ni preocupaciones, solo tú, en la profunda tranquilidad de tu hogar.

(FR) De temps en temps, vous aimez vous arrêter, vous asseoir et simplement regarder les choses qui vous entourent : des objets, des livres, des tableaux. Pas de délais, pas de soucis, juste vous, dans le calme profond de votre maison.





Poltrona HAIRPIN. L 86 P 91 H 80 cm.
Rivestimento in tessuto Patch 34.

HAIRPIN armchair. W 86 D 91 H 80 cm.
Upholstery in Patch 34 fabric.



Tavolini MEKKI.
 L 141 P 73 H 25 cm: tavolino ovale.
 Struttura in metallo in finitura
 Light Brown ME11, top in marmo
 Travertino MA04.
 L 50 P 50 H 40 cm: tavolino servetto.
 Struttura in metallo in finitura Light
 Brown ME11, top in vetro fumé VE05.
Madia bassa PETRA.
 L 227 P 49 H 49 cm.
 Struttura in finitura laccato
 Mastice Glossy LE27, inserto
 in marmo Silver Moon MA19.

MEKKI coffee tables.
 W 141 D 73 H 25 cm:
 oval coffee table.
 Metal structure in Light Brown ME11
 finish, Travertino MA04 marble top.
 W 50 D 50 H 40 cm: side table.
 Metal structure in Light Brown ME11
 finish, smoky glass VE05 top.
PETRA low sideboard.
 W 227 D 49 H 49 cm.
 Structure in Mastice Glossy LE27
 lacquered finish, Silver Moon MA19
 marble decorative element.



Dicono che poter godere della vista degli alberi fuori dalle proprie finestre abbia effetti sul benessere mentale e sulla creatività. Sì, è proprio il tuo caso.

(EN) They say looking at the trees outside your window has a positive effect on mental wellbeing and creativity. They could just be right.

(ES) Dicen que poder admirar los árboles a través de las ventanas favorece el bienestar mental y la creatividad. Sí, sin duda es tu caso.

(FR) On dit que pouvoir profiter de la vue sur les arbres depuis ses fenêtres a un effet bénéfique sur le bien-être mental et la créativité. Oui, c'est exactement votre cas.



Divani DECK.
L 248 P 102 H 83 cm: divano 3 posti.
Rivestimento in tessuto Texas 15.
L 288 P 102 H 83 cm: divano 3 posti
maxi. Rivestimento in pelle Polar 223.
Tavolini DECK.
L 120 P 120 H 37 cm: tavolino tondo
maxi. Rivestimento in tessuto Martin
102, top in marmo Travertino MA04.
L 60 P 60 H 49 cm: tavolino tondo
piccolo. Rivestimento in tessuto
Martin 102, top in Alpaca LE26.
Poltrona MANTA, madia bassa PETRA,
tappeto NOLAN.

DECK sofas.
W 248 D 102 H 83 cm: 3-er sofa.
Upholstery in Texas 15 fabric.
W 288 D 102 H 83 cm: 3-er maxi sofa.
Upholstery in Polar 223 leather.
DECK coffee tables.
W 120 D 120 H 37 cm: maxi round coffee
table. Upholstery in Martin 102 fabric,
Travertino MA04 marble top.
W 60 D 60 H 49 cm: small round
coffee table. Upholstery in
Martin 102 fabric, Alpaca LE26 top.
MANTA armchair, PETRA low sideboard,
NOLAN carpet.







Poltrona MANTA. L 92 P 87 H 97 cm.
Rivestimento in tessuto Patch 52.

MANTA armchair. W 92 D 87 H 97 cm.
Upholstery in Patch 52 fabric.



Ditre Italia



Tavolo COSMOS.
L 180 P 180 H 76 cm.
Gambe e top in finitura laccato
Mastice Glossy LE27 con inserto
centrale in vetro bronzato VE02.
Sedia VIGA, madia CIRCUS.

COSMOS table.
W 180 D 180 H 76 cm.
Legs and top in Mastice Glossy
LE27 lacquered finish with bronzed
glass VE02 central element.
VIGA chair, CIRCUS sideboard.





Sedia VIGA MIX. L 64 P 60 H 82 cm.
Struttura in metallo Light Brown ME11,
rivestimento in pelle Polar 212 e
tessuto Tape 305.

VIGA MIX chair. W 64 D 60 H 82 cm.
Light Brown ME11 metal structure,
upholstery in Polar 212 leather
and Tape 305 fabric.



Le tue cose in ordine, il silenzio, le luci spente.
Uscire è come mettere il tuo mondo in stand-by
per ritrovarlo, uguale e rassicurante, al tuo ritorno.

(EN) Everything is in its place.
The lights are off. The sound
of silence. Stepping outside
is like pressing pause on your
life; everything as it was,
and should be, on your return.

(ES) Tus cosas ordenadas,
el silencio, las luces apagadas.
Salir es como poner tu mundo
en pausa para encontrarlo,
inalterado y reconfortante,
al volver a casa.

(FR) Vos affaires rangées,
le silence, les lumières éteintes.
Sortir, c'est comme mettre
son monde entre parenthèses,
pour le retrouver intact
et rassurant à votre retour.



DIVANI / SOFAS

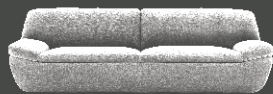

Deck 076-083



Isla/Isla Slim 084-089



Nube 090-095

POLTRONE / ARMCHAIRS



Hairpin 096-097



Isla 098-099



Manta 100-101

TAVOLI E SEDIE / TABLES & CHAIRS

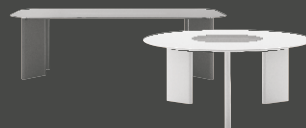

Cosmos 102-105



Bliss 106-107



Viga 108-109

TAVOLINI / COFFEE TABLES



Deck 110-111



Mekki 112-113

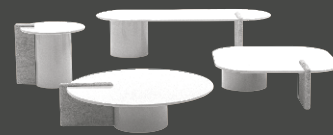

Petra 114-115

CONTENITORI E COMPLEMENTI / COMPLEMENTARY FURNITURE

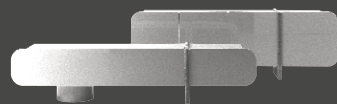

Petra 116-117



U Mirror 118-119

Overview

Ispirato ai ponti delle barche, Deck è un divano che unisce tradizione e avanguardia, tracciando una connessione tra la magia della nautica d'epoca e la sartorialità contemporanea. Nella scocca, slanciata e sagomata, si inseriscono cuscini che sembrano scomparire e un bracciolo inclinato. A rendere dinamica l'estetica orizzontale del divano sono volumi diagonali e piani laterali a tutta profondità che ne valorizzano le curve. Nella versione Matelassé, trapuntature sottili conferiscono un tocco di eleganza in più.



EN – Inspired by boat decks, this sofa blends tradition with innovation, combining the magic of period seafaring with contemporary tailoring. The sleek and shaped frame accommodates cushions that seem to disappear and a slanted armrest. The horizontal aesthetic of the sofa is made even more dynamic by the diagonal volumes and full-depth sides that showcase its curves. In the Matelassé version, the subtle quilting adds an extra touch of elegance.

ES – Inspirado en los puentes de los barcos, Deck es un sofá que combina tradición y vanguardia, creando un vínculo entre la magia de la navegación de antaño y la confección moderna. En el cuerpo, esbelto y contorneado, se integran cojines que parecen esfumarse y un reposabrazos inclinado. El rasgo que dinamiza la estética horizontal del sofá son los volúmenes diagonales y las superficies laterales de profundidad completa que resaltan las curvas. En la versión Matelassé, el sutil acolchado confiere un toque de elegancia añadida.

FR – Inspiré par les ponts des bateaux, Deck est un canapé qui allie tradition et avant-garde, en traçant un lien entre la magie du nautisme d'époque et la haute couture contemporaine. Sa corps élancé et façonné est doté de coussins qui semblent disparaître et d'un accoudoir incliné. L'esthétique horizontale du canapé est dynamisée par des volumes diagonaux et des plans latéraux en pleine profondeur qui accentuent ses courbes. Dans la version Matelassée, un matelassage subtil ajoute une touche d'élégance supplémentaire.

Dettagli e caratteristiche
Details and features



Composizione 1
Composition 1





Divano Deck 3 posti / Versione tessuto
Deck 3-er sofa / Fabric version



Divano Deck 3 posti maxi / Versione pelle
Deck 3-er maxi sofa / Leather version



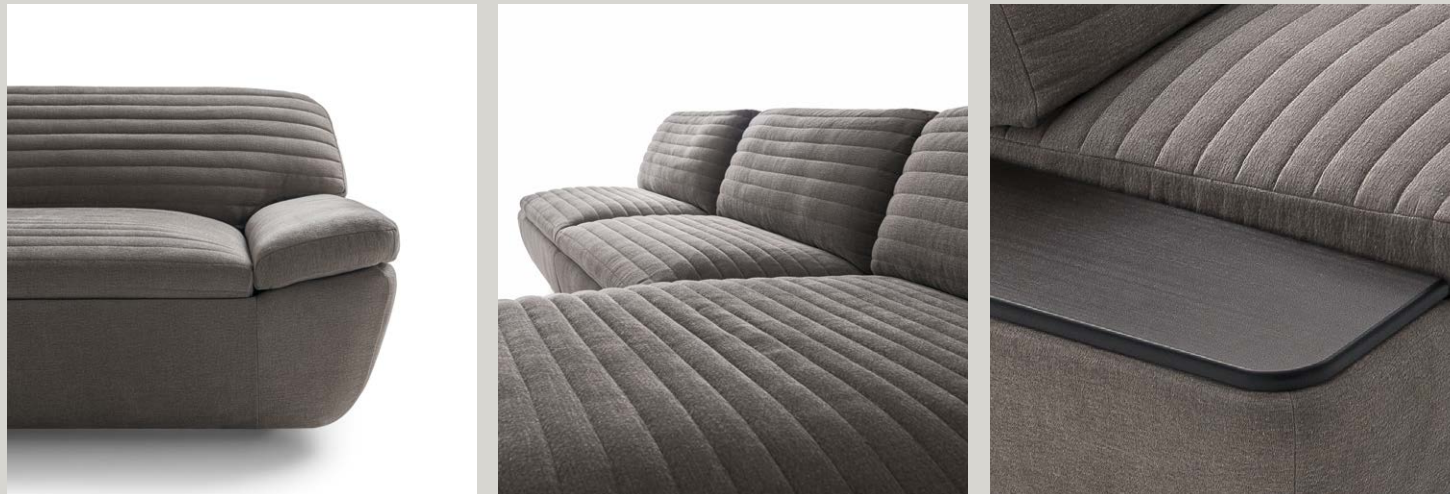

Composizione 2
Composition 2



**Divano 2 posti
2-er sofa**

Tessuto/Pelle
Fabric/Leather



**Dimensioni
Dimensions**

W 208 D 102 H 83 cm

**Divano 3 posti, 3 posti maxi
3-er sofa, 3-er maxi sofa**

Tessuto/Pelle
Fabric/Leather



**Dimensioni
Dimensions**

W 248 D 102 H 83 cm
W 288 D 102 H 83 cm

**Angolo tondo, Angolo tondo maxi
Rounded corner, maxi rounded corner**

Tessuto/Pelle
Fabric/Leather

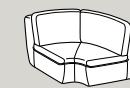

**Dimensioni
Dimensions**

W 127 D 127 H 83 cm
W 151 D 151 H 83 cm

**Centrale 1 posto
1-er central element**

Tessuto/Pelle
Fabric/Leather



**Dimensioni
Dimensions**

W 76 D 102 H 83 cm
W 96 D 102 H 83 cm
W 116 D 102 H 83 cm

**Centrale 2 posti, centrale 3 posti
2-er central element, 3-er central element**

Tessuto/Pelle
Fabric/Leather



**Dimensioni
Dimensions**

W 148 D 102 H 83 cm
W 188 D 102 H 83 cm
W 228 D 102 H 83 cm

**Elemento laterale
Lateral element**

Tessuto/Pelle
Fabric/Leather



**Dimensioni
Dimensions**

W 106 D 102 H 83 cm
W 125 D 102 H 83 cm
W 146 D 102 H 83 cm

**Elemento laterale
Lateral element**

Tessuto/Pelle
Fabric/Leather

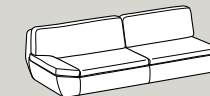

**Dimensioni
Dimensions**

W 178 D 102 H 83 cm
W 218 D 102 H 83 cm
W 258 D 102 H 83 cm

**Elemento laterale con piano in legno
Lateral element with wooden top**

Tessuto/Pelle + legno
Fabric/Leather + wood



**Dimensioni
Dimensions**

W 103 D 102 H 83 cm
W 123 D 102 H 83 cm
W 143 D 102 H 83 cm

**Chaise longue
Chaise longue**

Tessuto/Pelle
Fabric/Leather



**Dimensioni
Dimensions**

W 125 D 163 H 83 cm
W 145 D 163 H 83 cm

**Pouf
Footstool**

Tessuto/Pelle
Fabric/Leather



**Dimensioni
Dimensions**

W 75 D 75 H 43 cm
W 95 D 95 H 43 cm
W 115 D 115 H 43 cm

Divano 2 posti 2-er sofa	Dimensioni Dimensions			Divano 3 posti, 3 posti maxi 3-er sofa, 3-er maxi sofa	Dimensioni Dimensions		
Tessuto Fabric	W 208	D 102	H 83 cm	Tessuto Fabric	W 248	D 102	H 83 cm
					W 288	D 102	H 83 cm

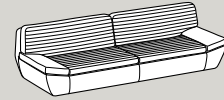
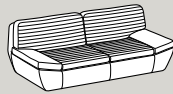

Angolo tondo, Angolo tondo maxi Rounded corner, maxi rounded corner	Dimensioni Dimensions			Centrale 1 posto 1-er central element	Dimensioni Dimensions		
Tessuto Fabric	W 127	D 127	H 83 cm	Tessuto Fabric	W 76	D 102	H 83 cm
	W 151	D 151	H 83 cm		W 96	D 102	H 83 cm
					W 116	D 102	H 83 cm



Centrale 2 posti, centrale 3 posti 2-er central element, 3-er central element	Dimensioni Dimensions			Elemento laterale Lateral element	Dimensioni Dimensions		
Tessuto Fabric	W 148	D 102	H 83 cm	Tessuto Fabric	W 106	D 102	H 83 cm
	W 188	D 102	H 83 cm		W 125	D 102	H 83 cm
	W 228	D 102	H 83 cm		W 146	D 102	H 83 cm

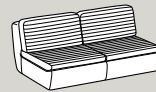

Elemento laterale Lateral element	Dimensioni Dimensions			Elemento laterale con piano in legno Lateral element with wooden top	Dimensioni Dimensions		
Tessuto Fabric	W 178	D 102	H 83 cm	Tessuto Fabric	W 103	D 102	H 83 cm
	W 218	D 102	H 83 cm		W 123	D 102	H 83 cm
	W 258	D 102	H 83 cm		W 143	D 102	H 83 cm

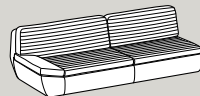

Chaise longue Chaise longue	Dimensioni Dimensions			Pouf Footstool	Dimensioni Dimensions		
Tessuto Fabric	W 125	D 163	H 83 cm	Tessuto Fabric	W 75	D 75	H 43 cm
	W 145	D 163	H 83 cm		W 95	D 95	H 43 cm
					W 115	D 115	H 43 cm



Suggerimenti di composizioni
Suggested compositions

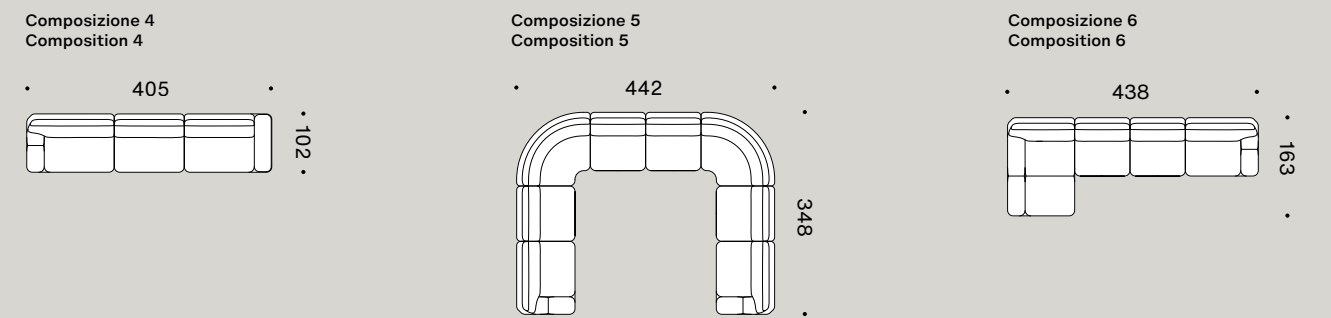
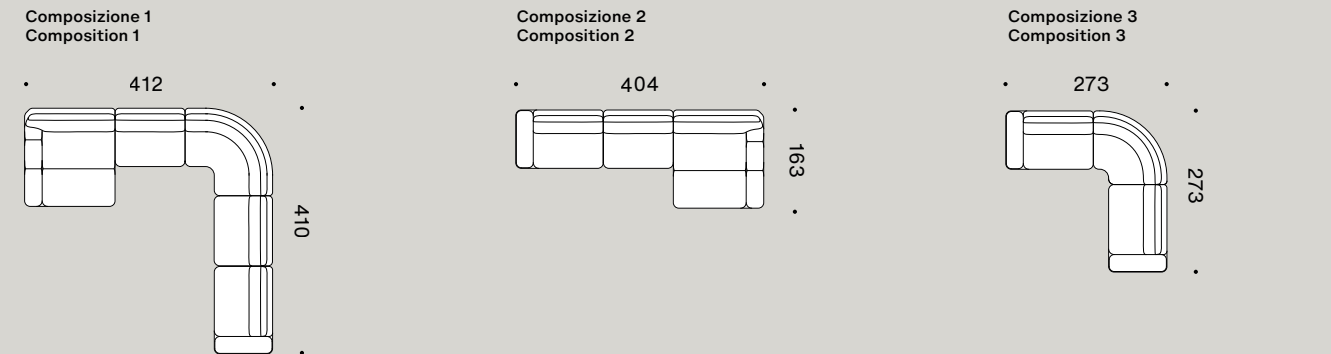

Rivestimento Deck Deck upholstery		Rivestimento Deck Matelassé Deck Matelassé upholstery	Piano in legno Wooden top
Tessuto Fabric	Pelle Leather	Tessuto Fabric	LE12 Grey wood

Dalla libertà di composizione e dal desiderio di informalità nasce un divano che è un arcipelago di forme arrotondate. Isole come sedute accoglienti e con morbidi cuscini da disporre a piacere, tra cui uno schienale ad angolo variabile che caratterizza l'insieme e si adatta ai corpi e allo spazio.



EN – Compositional freedom combined with a yearning for informality have given rise to a sofa consisting of an archipelago of rounded shapes. Islands providing comfortable seats, with soft cushions to be arranged to your liking, including a backrest with a variable tilt angle that distinguishes the ensemble and adapts to varying body shapes and to different surroundings.

ES – De la libertad compositiva y de la búsqueda de la informalidad nace un sofá que es un archipiélago de contornos redondeados. Islas en forma de asientos acogedores y con mullidos cojines que se pueden colocar libremente, uno de ellos para respaldo de ángulo variable que define el conjunto y se amolda a los cuerpos y al espacio.

FR – De la liberté de composition et du désir d'informalité est né un canapé qui est un archipel de formes arrondies. Des îlots comme des sièges accueillants avec des coussins moelleux à disposer à son gré, parmi lesquels un dossier à angle variable qui caractérise l'ensemble et s'adapte au corps et à l'espace.

Dettagli e caratteristiche
Details and features



Composizione 9
Composition 9









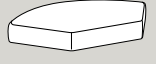

Composizione 10
Composition 10



Base chaise longue Chaise longue base	Dimensioni Dimensions	Base angolare Angular base	Dimensioni Dimensions
Tessuto Fabric	W 220 W 180	D 220 D 180	H 44 cm H 44 cm
	Isla Slim W 205 W 165 W 145	D 205 D 165 D 145	H 44 cm H 44 cm H 44 cm
Tessuto Fabric			W 180 D 180 H 44 cm
			Isla Slim W 165 D 165 H 44 cm
			

Base angolo tondo Rounded corner base	Dimensioni Dimensions	Base Base	Dimensioni Dimensions
Tessuto Fabric	W 130	D 130	H 44 cm
	Isla Slim W 115	D 115	H 44 cm
Tessuto Fabric			W 130 D 130 H 44 cm
			Isla Slim W 115 D 115 H 44 cm
			

Base rettangolare Rectangular base	Dimensioni Dimensions	Base con un lato rotondo Base with one rounded side	Dimensioni Dimensions
Tessuto Fabric	W 180 W 205 W 235 W 255	D 130 D 130 D 130 D 130	H 44 cm H 44 cm H 44 cm H 44 cm
	Isla Slim W 180 W 205 W 235 W 255	D 115 D 115 D 115 D 115	H 44 cm H 44 cm H 44 cm H 44 cm
Tessuto Fabric			W 230 D 130 H 44 cm
			Isla Slim W 230 D 115 H 44 cm
			

Base terminale curva Curved terminal base	Dimensioni Dimensions	Schienale Backrest	Dimensioni Dimensions
Tessuto Fabric	W 219	D 130-165	H 44 cm
	Isla Slim W 203	D 115-150	H 44 cm
Tessuto/pelle Fabric/leather		Pelle trapuntata Quilted leather	W 80 W 110
			D 37 D 37
			H 39 cm H 39 cm

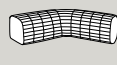
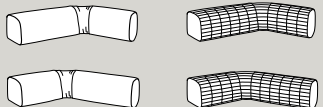
Schienale angolo Corner backrest	Dimensioni Dimensions	Schienale angolare Angular backrest	Dimensioni Dimensions
Tessuto/pelle Fabric/leather	W 109-155	D 109-89	H 39 cm
			
Pelle trapuntata Quilted leather			
			
Tessuto/pelle Fabric/leather		Pelle trapuntata Quilted leather	W 132-183
			D 109-89
			H 39 cm

Suggerimenti di composizioni
Suggested compositions

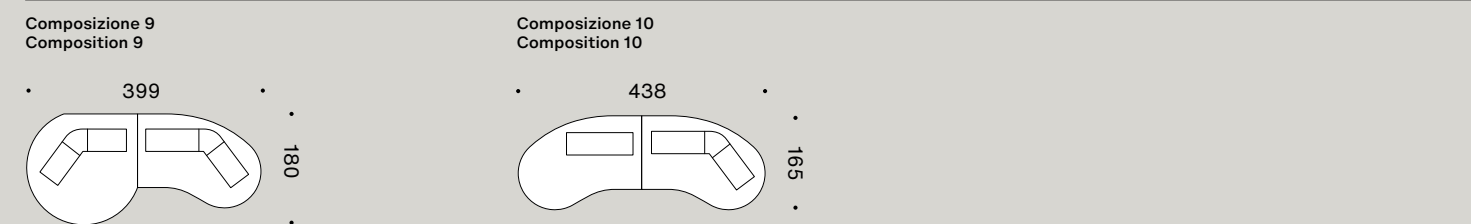
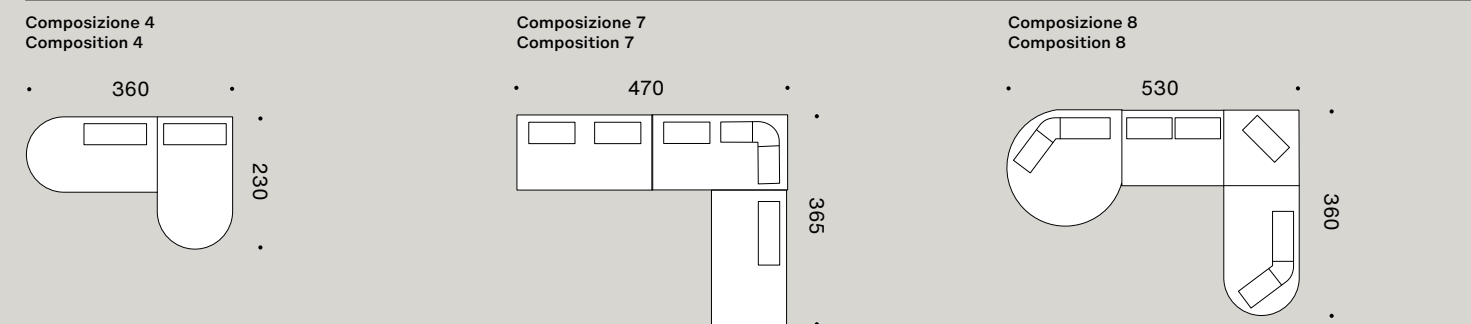
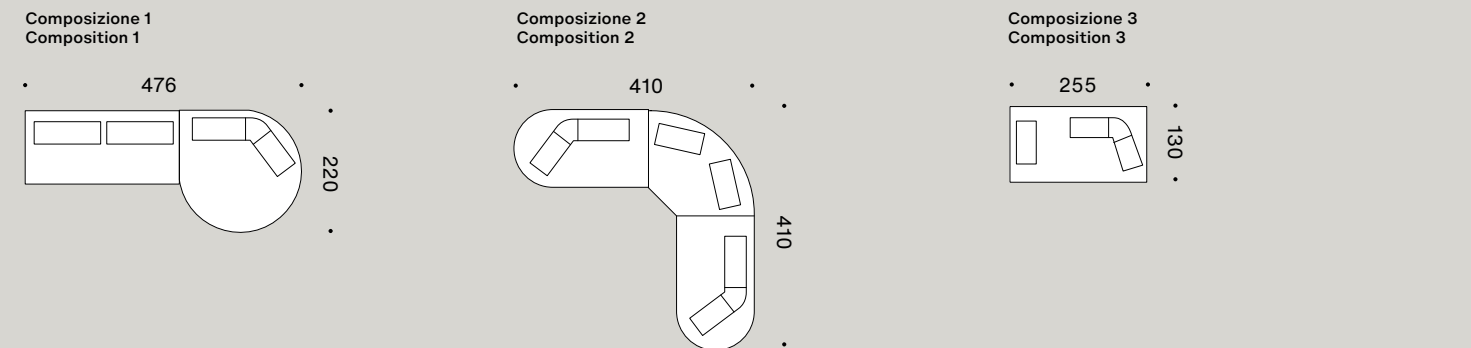

Rivestimento base Base upholstery	Rivestimento schienale Backrest upholstery		Rivestimento schienale trapuntato Quilted backrest upholstery	Profilo Profile
Tessuto Fabric	Tessuto Fabric	Pelle Leather	Pelle Leather	Tessuto Malaga o cucitura con ribattitura a un ago. Malaga fabric or single-needle stitching.
				

Dal desiderio di evocare una sensazione di sospensione e leggerezza nasce il divano Nube, ispirato all'impalpabilità delle nuvole. Gli elementi, da combinare tra loro per creare diverse configurazioni, sono tenuti insieme da un sistema d'aggancio invisibile, che sostiene la struttura e definisce i singoli volumi, donando al prodotto finale un'estetica morbida.



EN – Evoking the ethereal forms of a cloud, the Nube sofa is inspired by the idea of weightlessness and fragility. The elements, which can be combined to create different configurations, are held together by an invisible fastening system that supports the frame and defines its individual volumes, giving the end product its enticing cloud-like appearance.

ES – Del deseo de evocar una sensación de levitación y ligereza nace el sofá Nube, inspirado en la impalpabilidad de las nubes. Los elementos, que se combinan entre sí para crear diversas configuraciones, se unen con un sistema de enganche invisible, que sostiene la estructura y define cada volumen, aportando al producto final una estética delicada.

FR – Le canapé Nube, inspiré par l'impalpabilité des nuages, est né du désir d'évoquer une sensation de suspension et de légèreté. Les éléments, qui peuvent être combinés pour créer différentes configurations, sont maintenus ensemble par un système de fixation invisible qui soutient la structure et définit chaque volumes, conférant au produit final une esthétique douce.

Dettagli e caratteristiche
Details and features



Composizione 1
Composition 1





Composizione 2
Composition 2



Divano 3 posti, 3 posti maxi 3-er sofa, 3-er maxi sofa	Dimensioni Dimensions			Angolo aperto Open corner	Dimensioni Dimensions		
	Tessuto Fabric	W 260 W 290	D 104 D 104		H 75 cm H 75 cm	Tessuto Fabric	W 155

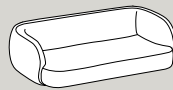

Centrale Central element	Dimensioni Dimensions			Chaise longue tonda Rounded chaise longue	Dimensioni Dimensions		
	Tessuto Fabric	W 111	D 104		H 75 cm	Tessuto Fabric	W 150

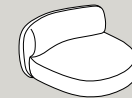

Chaise longue Chaise longue	Dimensioni Dimensions			Laterale 1 posto 1-er lateral element	Dimensioni Dimensions		
	Tessuto Fabric	W 125	D 150		H 75 cm	Tessuto Fabric	W 125



Laterale 1 posto tondo 1-er lateral rounded element	Dimensioni Dimensions			Terminale inclinato Slanted terminal element	Dimensioni Dimensions		
	Tessuto Fabric	W 160	D 104		H 75 cm	Tessuto Fabric	W 149

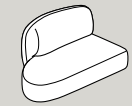

Terminale 1 posto 1-er terminal element	Dimensioni Dimensions			Pouf Footstool	Dimensioni Dimensions		
	Tessuto Fabric	W 130	D 104		H 75 cm	Tessuto Fabric	W 105



Suggerimenti di composizioni
Suggested compositions

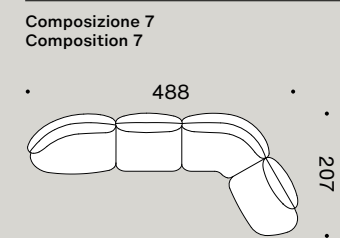
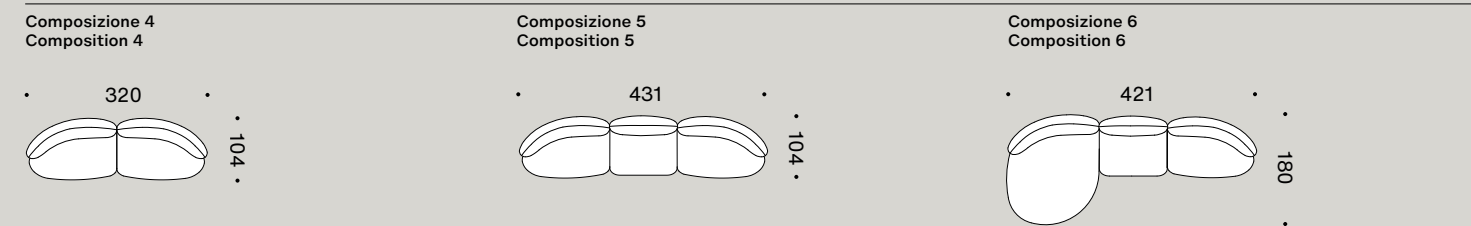
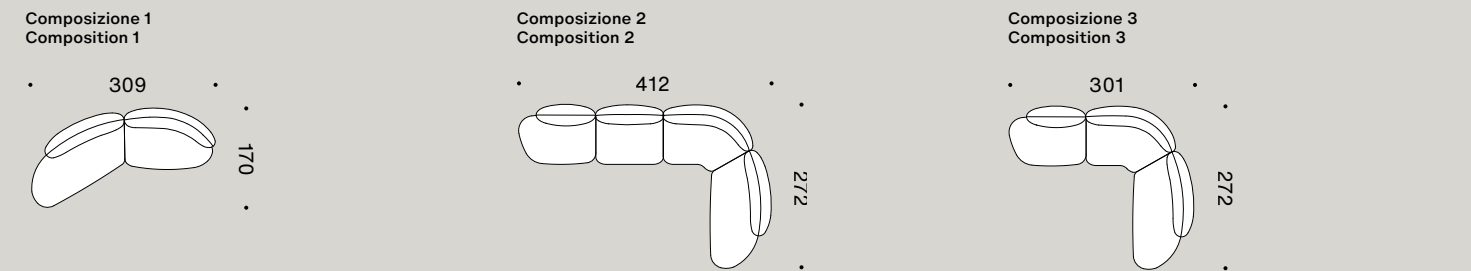

Rivestimento
Upholstery

Tessuto
Fabric



Un segno deciso, un gesto continuo che trasforma il movimento in forma. Il dettaglio distintivo della poltrona Hairpin è l'elemento cilindrico che ne disegna le gambe e i braccioli, avvolgendo lo schienale con un'unica linea senza interruzioni. Morbida ma architettonica, essenziale ma audace, Hairpin è un pezzo espressivo nelle linee ed equilibrato nelle proporzioni.



EN – A bold and continuous design that transforms movement into form. The distinctive detail of the Hairpin armchair is the cylindrical element that forms the legs and armrests, enveloping the backrest with a single unbroken line. Soft but architectural, simple yet bold, Hairpin is expressive in its profiles and balanced in its proportions.

ES – Rasgos decididos con una continuidad que transforma el movimiento en forma. El detalle distintivo del sillón Hairpin es el elemento cilíndrico que dibuja sus patas y reposabrazos, envolviendo el respaldo con una única línea sin interrupciones. Mullido pero arquitectónico, sobrio pero audaz, Hairpin es una pieza de líneas expresivas y proporciones equilibradas.

FR – Un signe net, un geste continu qui transforme le mouvement en forme. Le détail distinctif du fauteuil Hairpin est l'élément cylindrique qui souligne ses pieds et ses accoudoirs, en enveloppant le dossier d'une seule ligne continue. Doux et architectural, essentiel mais audacieux, Hairpin est une pièce expressive dans ses lignes et équilibrée dans ses proportions.

Dettagli e caratteristiche
Details and features



Poltrona
Armchair

Dimensioni
Dimensions

Tessuto/pelle
Fabric/leather

W 86 D 91 H 80 cm

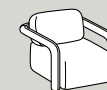

Rivestimento
Upholstery

Tessuto
Fabric

Pelle
Leather



A naturale completamento dell'omonimo divano arriva la poltrona Isla, che ne eredita i tratti distintivi: forme morbide e rotondità scolpite dolcemente, come plasmate dalla primordiale forza dell'acqua. Il risultato è una collezione in cui divano e poltrona dialogano in armonia, come isole di uno stesso arcipelago.



EN – A natural complement to the sofa of the same name, the Isla armchair also maintains its distinctive features: soft forms and delicately sculpted curves, as if shaped by the primordial force of water. The result is a collection in which sofa and armchair dialogue in harmony, like islands of the same archipelago.

ES – Para completar con naturalidad el sofá del mismo nombre llega el sillón Isla, que hereda de él sus rasgos distintivos: formas suaves y redondas esculpidas con delicadeza, como plasmadas por la fuerza primordial del agua. El resultado es una colección en la que el sofá y el sillón dialogan en armonía, como islas dentro de un mismo archipiélago.

FR – Le fauteuil Isla, complément naturel du canapé du même nom, en hérite les caractéristiques distinctives : des formes douces et des courbes délicatement sculptées, comme façonnées par la force primordiale de l'eau. Il en résulte une collection où le canapé et le fauteuil interagissent harmonieusement, comme des îles d'un même archipel.

Dettagli e caratteristiche
Details and features



Poltrona
Armchair

Dimensioni
Dimensions

Tessuto
Fabric

W 89 D 90 H 74 cm

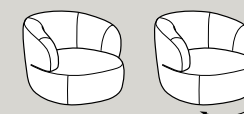

Rivestimento
Upholstery

Tessuto
Fabric



Come la creatura marina a cui è ispirata, la poltrona Manta è elegante e leggera, quasi dolcemente sospesa. Caratterizzata da un design organico fatto di curve armoniose, restituisce un'esperienza di seduta straordinaria, rivelandosi al contempo una presenza gentile, in cui rifugiarsi per godere di attimi di silenzio, calma e contemplazione.



EN – Like the marine creature after which it is named, the Manta armchair is light and elegant, almost appearing to gently hover above the floor. With its organic design made up of harmonious curves, it is both an extraordinary seating experience and a delicate presence, a place to take refuge and enjoy precious moments of silence, calm and contemplation.

ES – Al igual que el animal marino en el que se inspira, el sillón Manta es elegante y liviano, y parece flotar con elegancia. Con su característico diseño orgánico hecho de curvas armoniosas, ofrece al usuario una experiencia inigualable, erigiéndose al mismo tiempo como una agradable presencia en la que refugiarse para disfrutar momentos de silencio, tranquilidad y contemplación.

FR – Comme la créature marine qui l'a inspiré, le fauteuil Manta est élégant et léger, comme doucement suspendu. Caractérisé par un design organique fait de courbes harmonieuses, il offre une expérience d'assise extraordinaire, tout en se révélant comme une présence douce, dans laquelle se réfugier et savourer des moments de silence, de calme et de contemplation.

Dettagli e caratteristiche
Details and features



Poltrona
Armchair

Dimensioni
Dimensions

Tessuto/pelle
Fabric/leather

W 92 D 87 H 97 cm

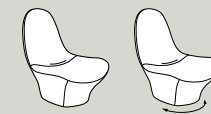

Rivestimento
Upholstery

Tessuto
Fabric

Pelle
Leather



Design Daniele Lo Scalzo Moscheri

pp. 038, 068

Un'opera d'arte funzionale che esalta la bellezza dei materiali e accende l'area dining di luce con il suo particolare gioco di riflessi. Ispirato ai pianeti e all'ordine dell'universo, il tavolo Cosmos unisce un'estetica solida, data dalle gambe con sezione ad asola, a un gioco di materiali nel top, trasformando la convivialità in un momento straordinario.



EN – A functional work of art that showcases the beauty of the materials and illuminates the dining area with its particular reflective effect. Inspired by the planets and the order of the universe, the Cosmos table combines robust oval-section legs with a multi-material top to turn dinner parties into moments to remember.

ES – Una obra de arte funcional que resalta la belleza de sus materiales e ilumina el comedor con su particular juego de reflejos. Inspirada en los planetas y en el orden del universo, la mesa Cosmos combina una estética sólida, definida por las patas con sección de círculo alargado, con un juego de materiales en el sobre, haciendo de los momentos en compañía una experiencia extraordinaria.

FR – Une œuvre d'art fonctionnelle qui met en valeur la beauté des matériaux et illumine la zone repas grâce à son jeu de reflets unique. Inspirée par les planètes et l'ordre de l'univers, la table Cosmos allie une esthétique robuste, conférée par les pieds à section ajourée, à un jeu de matières sur le plateau, transformant la convivialité en un moment extraordinaire.

Dettagli e caratteristiche
Details and features



Tavolo COSMOS. L 300 P 120 H 76 cm.
Gambe in finitura laccato Mastice Glossy LE27, piano in marmo Silver Moon MA19 con inserto centrale in vetro bronzato VE02.

COSMOS table. W 300 D 120 H 76 cm.
Legs in Mastice Glossy LE27 lacquered finish, Silver Moon MA19 marble top with bronzed glass VE02 central element.

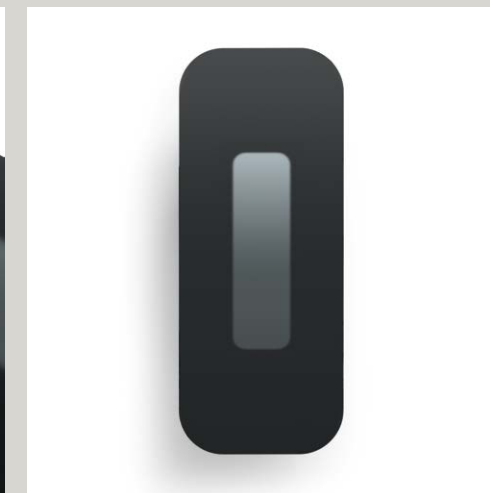

Tavolo COSMOS. L 300 P 120 H 76 cm.
Gambe in finitura laccato Antracite LE01, piano in vetro fumè VE05 a gradiente.

COSMOS table. W 300 D 120 H 76 cm.
Legs in Antracite LE01 lacquered finish, gradient smoky VE05 glass top.

Dettagli e caratteristiche
Details and features



Tavolo COSMOS. L 180 P 180 H 76 cm.
Gambe e top in finitura laccato
Mastice Glossy LE27 con inserto
centrale in vetro bronzato VE02.

COSMOS table. W 180 D 180 H 76 cm.
Legs and top in Mastice Glossy LE27
lacquered finish with bronzed glass VE02
central element.



Tavolo rettangolare in laccato
e inserto in vetro
Rectangular lacquered table
with glass central element

Dimensioni
Dimensions

Laccato + vetro
Lacquering + glass

W 270 D 110 H 76 cm
W 300 D 120 H 76 cm



Tavolo rotondo in laccato
e inserto in vetro
Round lacquered table
with glass central element

Dimensioni
Dimensions

Laccato + vetro
Lacquering + glass

W 160 D 160 H 76 cm
W 180 D 180 H 76 cm



Tavolo rettangolare con top
in marmo e inserto in vetro
Rectangular table with marble
top and glass central element

Dimensioni
Dimensions

Laccato + marmo + vetro
Lacquering + marble + glass

W 270 D 110 H 76 cm
W 300 D 120 H 76 cm



Tavolo rotondo con top in marmo
e inserto in vetro
Round table with marble top
and glass central element

Dimensioni
Dimensions

Laccato + marmo + vetro
Lacquering + marble + glass

W 160 D 160 H 76 cm
W 180 D 180 H 76 cm



Tavolo rettangolare con piano in vetro
Rectangular table with glass top

Dimensioni
Dimensions

Laccato + vetro
Lacquering + glass

W 270 D 110 H 76 cm
W 300 D 120 H 76 cm

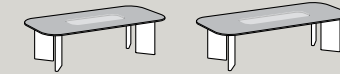

Tavolo rotondo con piano in vetro
Round table with glass top

Dimensioni
Dimensions

Laccato + vetro
Lacquering + glass

W 160 D 160 H 76 cm
W 180 D 180 H 76 cm

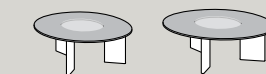

Finiture basamento
Base finishings

LE01
Antracite



LE27
Mastice
Glossy



LE28
Deep Brown
Glossy



Piano in laccato
Lacquered top

LE27
Mastice
Glossy



LE28
Deep Brown
Glossy



Piano in marmo
Marble top

MA02
Carrara
Bianco



MA06
Nero
Marquinia



MA08
Grigio
Carnico



MA09
Spiderman



MA19
Silver
Moon



Piano in vetro
Glass top

VE05
Fumè



Inserto in vetro
Glass central element

VE02
Bronzato



VE05
Fumè



Design Stefano Spessotto

p. 041

Dal contrasto fra solidità e morbidezza emerge l'identità peculiare della sedia Bliss, metafora di un raggiunto equilibrio. Completamente imbottita e rivestita, ha linee decise ispirate al mondo marino: lo schienale con design a martello, che si estende fino a diventare gamba posteriore, è ispirato alla testa di uno squalo.



EN – From the contrast between solidity and softness comes the idiosyncratic Bliss chair, a metaphor for balance. Completely upholstered and covered, its bold profiles are inspired by the nautical world: the backrest with hammer design, which extends down to become the back leg, is inspired by the head of a shark.

ES – Del contraste entre solidez y ductilidad surge la peculiar identidad de la silla Bliss, metáfora de un equilibrio alcanzado. Completamente acolchada y tapizada, presenta líneas decididas inspiradas en el mundo marino: el respaldo con forma de martillo, que se prolonga hasta convertirse en pata trasera, se inspira en la cabeza de un tiburón.

FR – L'identité distinctive de la chaise Bliss émerge du contraste entre solidité et douceur, métaphore d'un équilibre atteint. Entièrement rembourrée et revêtue de tissu, elle présente des lignes nettes inspirées du monde marin : le dossier en forme de marteau, qui se prolonge pour former le pied arrière, s'inspire de la tête d'un requin.

Dettagli e caratteristiche
Details and features



Sedia
Chair

Dimensioni
Dimensions

Tessuto/pelle
Fabric/leather

Mix pelle + tessuto
Mix leather + fabric

W 55

D 62

H 81 cm



Rivestimento
Upholstery

Tessuto
Fabric

Pelle
Leather

Mix pelle + tessuto
Mix leather + fabric



Viga nasce dall'incontro tra due icone del design del Novecento: l'archetipica sedia a sbalzo, in cui la seduta sembra sospesa in aria, e l'avvolgente poltroncina a pozzetto. Questa fusione tra rigore e morbidezza la trasforma in un oggetto espressivo e trasversale, capace di abitare con naturalezza sia ambienti classici che spazi contemporanei.



EN – Viga is born from a combination of two 20th century design icons: the archetypal cantilever chair, which appears to float in the air, and the enveloping tub armchair. This meeting of rigour and delicacy makes it an expressive and versatile object that is perfectly at home in both classic environments and contemporary spaces.

ES – Viga nace de la confluencia de dos iconos del diseño del siglo XX: la arquetípica silla en voladizo, donde el asiento parece flotar en el aire, y el envolvente sillón con respaldo. Esta fusión entre rigor y suavidad la transforma en una pieza expresiva y transversal, capaz de integrarse con naturalidad en ambientes tanto clásicos como modernos.

FR – Viga est née de la rencontre entre deux icônes du design du XX^e siècle : l'archétypale chaise en porte-à-faux, dont l'assise semble suspendue dans les airs, et l'enveloppant fauteuil cabriolet. Cette fusion de rigueur et de douceur en fait un objet expressif et transversal, capable d'habiter naturellement les espaces classiques et contemporains.

Dettagli e caratteristiche
Details and features



Sedia
Chair

Dimensioni
Dimensions

Tessuto/pelle
Fabric/leather

Mix pelle + tessuto
Mix leather + fabric

W 64

D 60

H 82 cm



Finiture struttura
Structure finishes

ME11

Light Brown

ME13

Peltro



Rivestimento
Upholstery

Tessuto

Fabric



Pelle

Leather



Mix pelle + tessuto

Mix leather + fabric

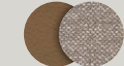

Pensata per accompagnare l'omonimo divano, la collezione di tavolini Deck è caratterizzata da volumi inclinati, ispirati alle carene delle barche. Diverse tipologie di piani poggiano su una morbida base imbottita, che lavora sul tema della morbidezza trasformando un oggetto rigido in un manufatto sartoriale.



EN – Designed to accompany the sofa of the same name, the collection of Deck coffee tables is characterised by slanted volumes inspired by the hulls of ships. Different types of top sit on a supple upholstered base that emphasises the idea of softness, transforming a rigid object into an expertly tailored product.

ES – Concebida para acompañar al sofá del mismo nombre, la colección de mesas de centro Deck se caracteriza por volúmenes inclinados, inspirados en las quillas de los barcos. Diversos tipos de sobre descansan sobre una mollida base acolchada, que se articula en torno a la suavidad, transformando una pieza rígida en un producto de confección.

FR – Conçue pour accompagner le canapé du même nom, la collection de tables basses Deck se caractérise par des volumes inclinés, inspirés des coques de bateaux. Différents types de plateaux reposent sur une douce base rembourrée, jouant sur le thème de la douceur et transformant un objet rigide en un produit sur mesure.

Dettagli e caratteristiche
Details and features



Tavolino tondo senza piano Round table without top			Dimensioni Dimensions			Piano per tavolino tondo in legno o marmo Round wooden or marble coffee table top			Dimensioni Dimensions		
Tessuto/pelle Fabric/leather	W 60 W 90 W 120	D 60 D 90 D 120	H 47 cm H 35 cm H 35 cm	Legno/marmo Wood/marble	W 58 W 88 W 118	D 58 D 88 D 118	H 2 cm H 2 cm H 2 cm				
Rivestimento base Base upholstery			Piano in legno Wooden top								
Tessuto Fabric	Pelle Leather		LE12 Grey wood	LE26 Alpaca							
Piano in marmo Marble top											
MA01 Dark Emperador	MA02 Carrara Bianco	MA04 Travertino	MA06 Nero Marquinia	MA08 Grigio Carnico	MA09 Spiderman	MA10 Rosso Levanto	MA11 Sequoia Brown	MA19 Silver Moon			

Dare piena espressione ai materiali che li compongono, rivelando ogni dettaglio senza nascondere nulla. Questa l'idea da cui nascono i tavolini Mekki, dove ogni elemento della struttura metallica, che abbraccia il top, rimane a vista. Il nome è un omaggio alla tecnica giapponese della placcatura del metallo, e pone l'attenzione sulla lavorazione delle superfici.



EN – Giving the constituent materials full freedom of expression, revealing every detail without hiding anything. This is the concept behind the Mekki coffee tables, where every element of the metal frame that embraces the top is on full view. The name is a homage to the Japanese metal plating technique and focuses the attention on the surface finishes.

ES – Dar una total libertad expresiva a los materiales que las componen, revelando cada detalle sin ocultar nada. Esta es la idea en la que se basan las mesas de centro Mekki, donde cada elemento de la estructura metálica, que envuelve el sobre, se mantiene a la vista. El nombre rinde homenaje a la técnica japonesa del chapado de metales, y centra la atención en la elaboración de las superficies.

FR – Donner pleinement expression aux matériaux qui les composent, révéler chaque détail sans rien cacher. C'est le concept des tables basses Mekki, où chaque élément de la structure métallique qui enveloppe le plateau reste visible. Le nom rend hommage à la technique japonaise de plaquage des métaux et met l'accent sur le traitement des surfaces.

Dettagli e caratteristiche
Details and features



Tavolino servetto Side table	Dimensioni Dimensions			Tavolino ovale Oval coffee table	Dimensioni Dimensions		
Metallo + marmo/vetro Metal + marble/glass	W 50	D50	H 40 cm	Metallo + marmo/vetro Metal + marble/glass	W 141	D 73	H 25 cm



Finiture struttura
Structure finishes

ME11
Light Brown



ME13
Peltro



Piano in vetro
Glass top

VE02
Bronzato



VE05
Fumè



VE13
Oxide Mirror



Piano in marmo
Marble top

MA01
Dark
Emperador



MA02
Carrara
Bianco



MA04
Travertino



MA06
Nero
Marquinia



MA08
Grigio
Carnico



MA09
Spiderman



MA10
Rosso
Levanto



MA11
Sequoia
Brown



MA19
Silver
Moon



I tavolini Petra si affiancano tra loro in un gioco di equilibri e proporzioni. La collezione traduce la morbidezza delle forme in un linguaggio brutalista, fatto di volumi scultorei puri e incastri.













EN – The Petra coffee tables are mixed and matched in a clever exploration of equilibriums and proportions. The collection translates the softness of the forms into a Brutalist language made up of pure sculptural volumes and joints.

ES – Las mesas de centro Petra se combinan entre sí con un juego de equilibrios y proporciones. La colección traduce la suavidad de las formas en un lenguaje brutalista, hecho de volúmenes escultóricos puros y estructuras encajadas.

FR – Les tables basses Petra sont disposées côte à côte dans un jeu d'équilibre et de proportions. La collection traduit la douceur des formes dans un langage brutaliste, fait de volumes sculpturaux purs et d'éléments encastrés.

Dettagli e caratteristiche
Details and features



Tavolino servetto Side table	Dimensioni Dimensions	Tavolino quadro Square coffee table	Dimensioni Dimensions
Laccato + laccato/marmo Lacquering + lacquering/marble	W 50 D 50 H 48 cm	Laccato + laccato/marmo Lacquering + lacquering/marble	W 90 D 90 H 29 cm
			
Tavolino rettangolare alto High rectangular coffee table	Dimensioni Dimensions	Tavolino tondo Round coffee table	Dimensioni Dimensions
Laccato + laccato/marmo Lacquering + lacquering/marble	W 160 D 60 H 39 cm	Laccato + laccato/marmo Lacquering + lacquering/marble	W 95 D 95 H 29 cm
			
Finiture struttura, piano e inserto Structure, top, and decorative element finishes		Finitura inserto marmo Marble decorative element finishes	
LE01 Antracite	LE27 Mastice Glossy	LE28 Deep Brown Glossy	MA02 Carrara Bianco
			
			MA06 Nero Marquinia
			
			MA19 Silver Moon
			

Design Stefano Spessotto

pp. 042, 057

Una collezione di madie dai volumi puri, linee rigorose e onestà della forma. Come negli omonimi tavolini l'ispirazione è brutalista e ha l'obiettivo di trasformare un complemento in un elemento scultoreo, rendendolo protagonista.



EN – A collection of sideboards with pure volumes, rigorous profiles and honest forms. Like with the coffee tables, the inspiration is Brutalist and the aim is to transform an accessory into a sculptural element that takes centre stage.

ES – Una colección de aparadores de volúmenes puros, líneas rigurosas y sinceridad formal. Al igual que las mesas de centro, se inspira en el brutalismo con el objetivo de transformar un complemento en un elemento escultórico, haciéndolo protagonista.

FR – Une collection de bahuts aux volumes purs, aux lignes rigoureuses et à la forme authentique qui. Comme pour les tables basses, s'inspire du brutalisme et vise à transformer un complément en un élément sculptural, en le rendant protagoniste.

Dettagli e caratteristiche
Details and features



Madia bassa
Low sideboard

Dimensioni
Dimensions

Laccato + laccato/marmo
Lacquering + lacquering/marble

W 227 D 49 H 49 cm

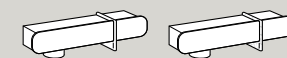

Madia alta
High sideboard

Dimensioni
Dimensions

Laccato + laccato/marmo
Lacquering + lacquering/marble

W 229 D 49 H 72 cm

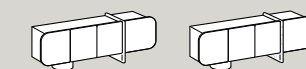

Finiture struttura, piano e inserto
Structure, top, and decorative element finishes

LE01 Antracite
LE27 Mastice Glossy
LE28 Deep Brown Glossy



Finitura inserto marmo
Marble decorative element finishes

MA02 Carrara Bianco
MA06 Nero Marquinia
MA19 Silver Moon



U Mirror

COMPLEMENTARY FURNITURE

Design Nika Zupanc

▮ p. 045

Lo specchio U Mirror è un'elegante esplorazione del tema della metamorfosi. Al centro dell'ovale, una curva a U crea una connessione fluida tra la base metallica e la superficie riflettente, dando vita a un volume che appare come un'unica entità compatta. La U funge da piano d'appoggio, ampliando con discrezione la funzione dell'oggetto senza comprometterne la purezza scultorea.



U MIRROR

COMPLEMENTARY FURNITURE

EN – The U Mirror is an elegant exploration of the idea of the metamorphosis. At the centre of the oval, a U-shaped curve creates a fluid connection between the metal base and the reflective surface, creating what appears to be a single compact object. The U acts as a shelf, discreetly expanding the function of the object without compromising its sculptural purity.

ES – El espejo U Mirror es una elegante exploración del tema de la metamorfosis. En el centro del óvalo, una curva en U crea un fluido nexo entre la base metálica y la superficie reflectante, dando vida a un volumen con aspecto de una única entidad compacta. La U sirve de superficie de apoyo, ampliando con discreción la función del objeto sin comprometer su pureza escultórica.

FR – Le miroir U Mirror est une exploration élégante du thème de la métamorphose. Au centre de l'ovale, une courbe en U crée une liaison fluide entre la base métallique et la surface réfléchissante, donnant vie à un volume qui apparaît comme une entité compacte unique. Le U sert de surface d'appui, étendant discrètement la fonction de l'objet sans compromettre sa pureté sculpturale.

Dettagli e caratteristiche
Details and features



Specchio
Mirror

Dimensioni
Dimensions

Specchio + metallo
Mirror + metal

W 80 D 23 H 194 cm



Finiture struttura
Frame finishings

ME11
Light Brown



Vetro
Glass

VE01
Trasparente



Concept and styling:
beatricerossettistudio
+
Claudia Ferrari e Wilson Polegato

Photography:
Gionata Xerra,
Photografica

Graphic design:
Designwork

Colour separation:
LuceGroup

Printed in Italy:
Grafiche Antiga Spa
4.2026

Thanks to:
Anna Vinzi
Chiara Belloni
courtesy Galleria L'Affiche
Francesca Zoboli
courtesy Galleria L'Affiche
KDLN
Luceplan
Simone Negri
courtesy Esh Gallery



Ditre
italia

